

Installation Manual

100, 200, 300 Series HPC
High Performance Concrete

Trench Drain Systems by Swift Drain

Trench Drain Materials | 646-227-0910

info@trenchdrainmaterials.com



Modular Range

200 Series Trench drain system is a full range of modular channels with gratings. 200 Series is made of environmentally harmless 200 Series HPC (High Performance Concrete); systems include catch basins, front/end caps, no hub bottom outlets and other accessories.

When installed correctly, 200 Series products are designed to withstand up to class E for trench drain with galvanized or stainless steel rails and up to class F for trench drain with cast iron rail, classified by EN 1433/DIN 19580 (The only standards written specifically for trench drain systems).

Contents	
Getting started	x
Health and Safety	x
Installation section	x
1. Excavation	x
2. On-site Fabrication	x
3. Catch basin connections	x
4. Pipe Connections	x
5. Connection with underground Piping	x
6. Positioning of Channels	x
- Patty Method	x
- Supported Method	x
- Suspension Method	x
7. Pouring Concrete	x
8. Pavement Finishing	x
- Concrete	x
- Asphalt	x
- Pavers	x
9. Fit Grates	x
10. Final inspection & Maintenance	x

200 Series products should be handled with care as they can be damaged by impact from other product or machinery.

Typical equipment necessary for installation may include:

- *Excavating equipment*
- *String-line and laser level*
- *Measuring tools*
- *Masonry drill, grinder and/or saw*
- *Rubber mallet*

- *Concrete - 4,000 psi minimum compressive strength*
- *Eye protection, gloves, breathing protection*
- *Concrete vibrator*
- *Shovel, trowel, rake, hammer*

Health and Safety

200 Series is free of synthetic resins, curing agents, heavy metals and VOC.



200 Series is certified by the Institute of Building Biology (Institut für Baubiologie Rosenheim GmbH) to be 100% sustainable, and completely harmless to the environment.



200 Series has A+ fire rating.

The main hazards are:

- Inhalation of dust from grinding, cutting or drilling.

Eye protection, breathing protection and gloves, should be worn to avoid these hazards.

Grates made from metals are either cast or fabricated.

The main hazards are:

- Abrasive damage/cuts to hands.
- Inhalation of dust from grinding or cutting.
- Grinding, cutting, etc. may generate sparks; flammable items should be removed from the area.

Eye protection, breathing protection and gloves, should be worn to avoid these hazards. Operations should be conducted away from areas of fire or explosion hazard.

Installation Sections

The supplied illustrations are a guide for typical ground conditions only and may not be specific to your project. Engineering advice and direction should always be given priority.

An installed 200 Series Trench Drain System should incorporate the following:

- Correct grate type
- Correct channel type and size
- Minimum grade 4,000 psi compressive strength cement concrete surround
- Surrounding concrete dimensions are **minimum** dimensions and engineering guidance should be taken to confirm appropriate needs and dimensions for any specific project

Poor site conditions and low load bearing pavement will require an increase in these dimensions to meet both vertical and lateral loads.

Reinforcing steel may be required within the slab and around the trench drain. Engineering guidance should be taken to confirm appropriate needs and dimensions for any specific project.

Concrete pavement - load class A-F

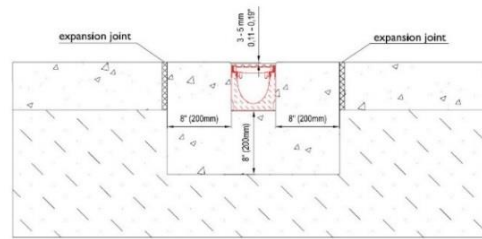

Asphalt pavement – load class A-E

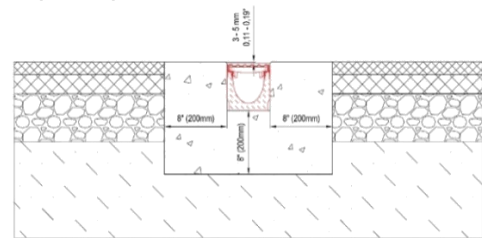

Paver pavement - load class A-E

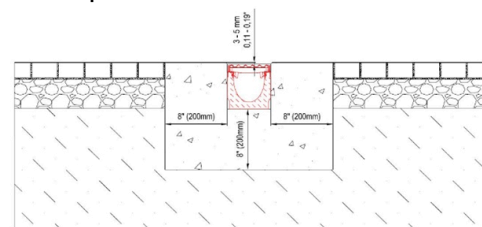

Asphalt pavement – Hidden concrete – load class A-E

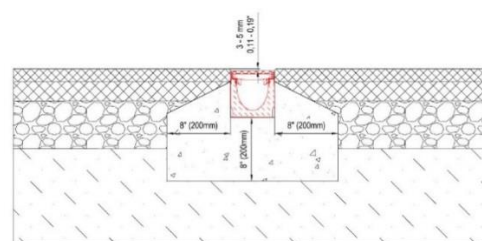

Paver pavement – Hidden concrete – load class A-E

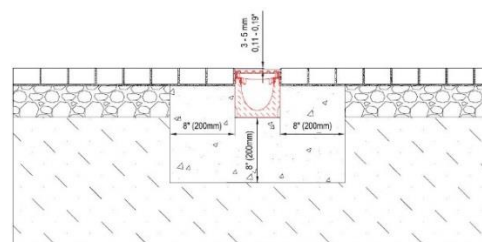

1. Excavation

Excavate trench to accommodate the drain system. Excavations must be made around the center line of proposed drainage run and catch basin.

The trench excavation must be large enough to accommodate each of the following:

- Channel/catch basin width and depth dimensions
- Surrounding concrete dimensions*
- Compacted gravel base
- For sloped systems, stepped slope or combined slope, excavate base of trench to roughly follow fall of trench run

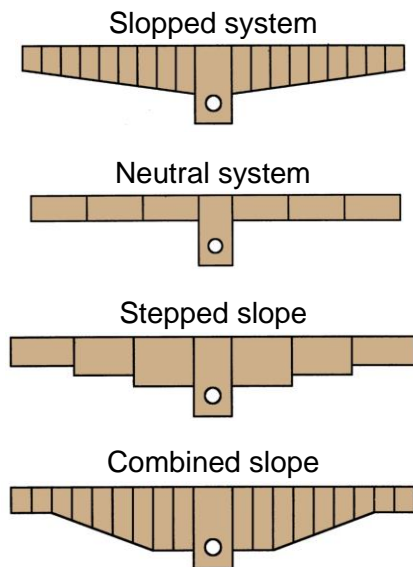

Ensure loose material is removed from trench and base is well compacted.

Run a string line or laser at finished surface along full length of proposed trench run to ensure trench is installed to grade.

In concrete pavements ensure an allowance is made for expansion/control joints, if necessary, to allow movement due to thermal expansion/contraction.

Engineered and site specific gravel base requirements should always be met. Local codes should always be checked.

As a general reference 200 Series offers the following gravel base dimensions for various load class requirements and its rail types.

For galvanized and stainless steel rails trench drains

Channel Nominal Width		Load Class				
		A 15	B 125	C 250	D 400	E 600
NW1 00	4"	100 mm	100 mm	150 mm	150m m	200m m
		4"	4"	6"	6"	8"
NW1 50	6"	150 mm	150 mm	200 mm	200m m	250 mm
		6"	6"	8"	8"	10"
NW2 00	8"	150 mm	150 mm	200 mm	200 mm	250 mm
		6"	6"	8"	8"	10"
NW3 00	12"	200 mm	250 mm	250 mm	300 mm	300 mm
		8"	8"	10"	12"	12"

For cast iron rails trench drains

Channel Nominal Width		Load Class					
		A 15	B 125	C 250	D 400	E 600	F 900*
NW 100	4"	100 mm	100 mm	150 mm	150 mm	200 mm	200 mm
		4"	4"	6"	6"	8"	8"
NW 150	6"	150 mm	150 mm	200 mm	200 mm	250 mm	250 mm
		6"	6"	8"	8"	10"	10"
NW 200	8"	150 mm	150 mm	200 mm	200 mm	250 mm	250 mm
		6"	6"	8"	8"	10"	10"
NW 300	12"	200 mm	250 mm	250 mm	300 mm	300 mm	300 mm
		8"	8"	10"	12"	12"	12"

2. On-Site Fabrications

When cutting channels and/or grates, gloves, protective eye wear and respirator or mask are recommended.

Cutting channels is required to form miters, tee junctions and non-standard lengths. Most fabrications can be completed on site.

Channels can be cut with a masonry or diamond disc saw. Gratings should be cut

with band saw, or similar, with suitable metal cutting blade.

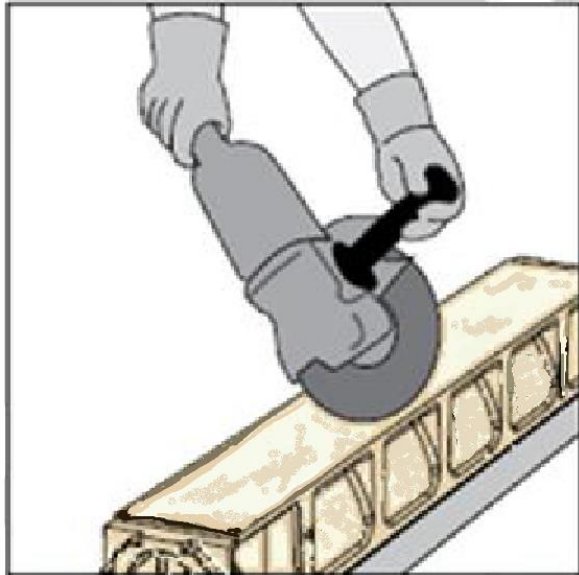

A standard construction glue can be used to bond cut surfaces together. Simply apply adhesive to both cut ends and push fit together, then allow to dry. Remove any extra adhesive from inside the channel surface before it hardens.

If corrosive liquids are transported in trench, joints should be properly sealed. Ensure the sealant/adhesive used is chemically resistant.

Miters

Mitered joints are formed by cutting channels to required angle and butting together. For 90° angle, miter cuts of 45° are required.

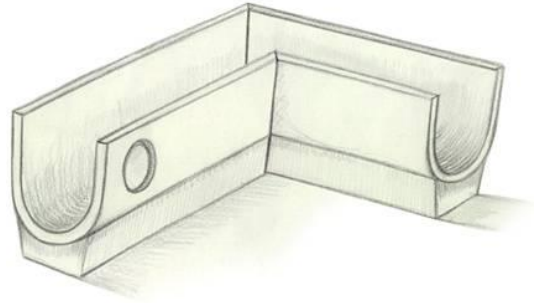

For heavy duty applications, mitered grates are not recommended. A tee joint is suggested to give the grating maximum support.

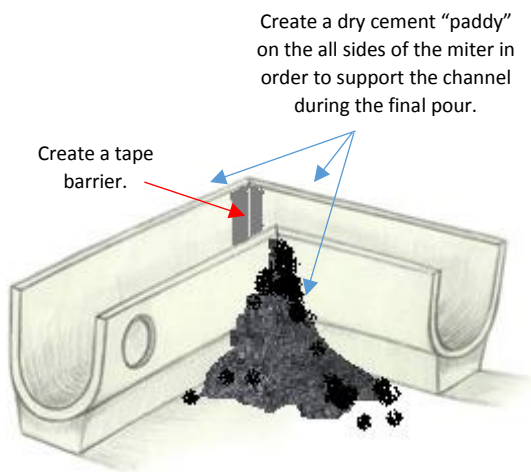
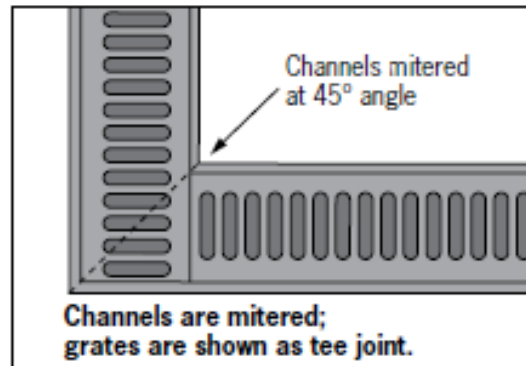

Tee Junctions

Tee junctions are formed when an opening is cut into the side of one channel and another channel is butted up to this opening.

On full meter channels; mark the area in the channel wall to be removed by butting channels together and marking profile of interior of channel.

Edge rail should be left intact to provide additional strength and seating for grate.

2. Connect discharge piping to catch basin adapter using a no hub coupling

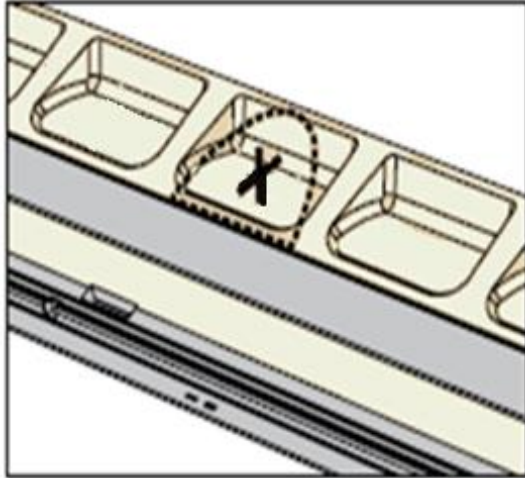

Catch Basin – Cut Out

- Use cut-off tool, reciprocating saw or band saw to cut opening for required height channel connection. (Bracing may be necessary).

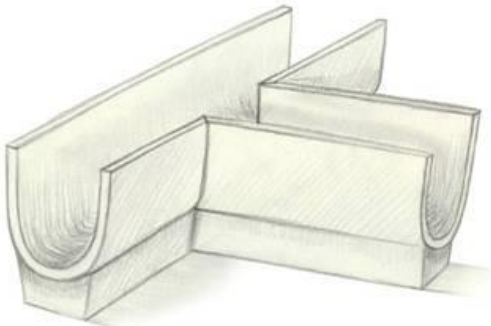

3. Catch basin Connections

Removal of knockout or cut hole:

1. Identify and mark area to be removed
2. Material removal

Note: 12" and 8" catch basin require a pipe adapter if cast iron soil pipe or PVC is used.

1. Insert pipe adapter as shown

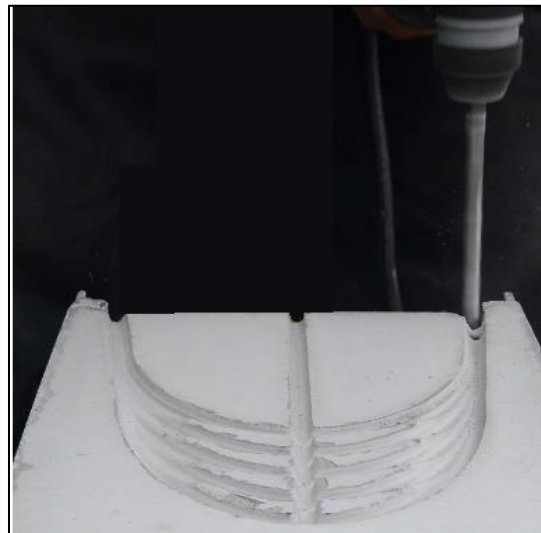

Use a grinder to dress or enlarge corners for proper fitting.

3. Insert the channel into socket and seal using appropriate sealant/adhesive.



If corrosive liquids are transported in trench, ensure sealant or adhesive is chemically resistant.

4. Pipe Connections

ATTENTION: Use protective glasses and respiratory protection when cutting and drilling 200 Series channels

Removal of knockout, or cut hole:

1. Identify and mark area to be removed.
2. Remove drill-out. Use cut-off tool, reciprocating saw or band saw to cut opening for required height channel connection. (Bracing may be necessary).

Core Drill

Using correct size diamond core drill, remove channel/catch basin wall/base to fit pipe.

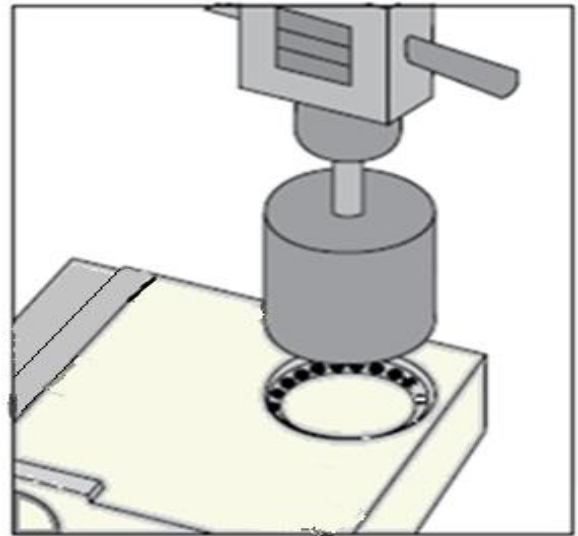

Stitch Drill

- Using concrete drill bit, pierce the channel every 1/8th of an inch around drill-out or marked area.

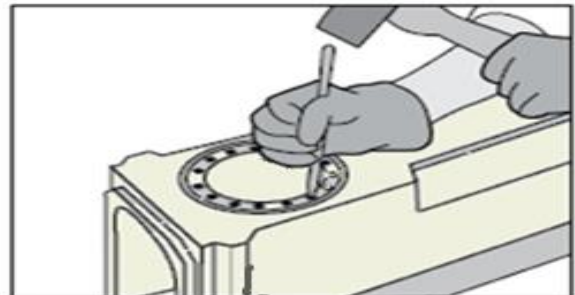

- From inside of channel, carefully tap out inside of perforated area.

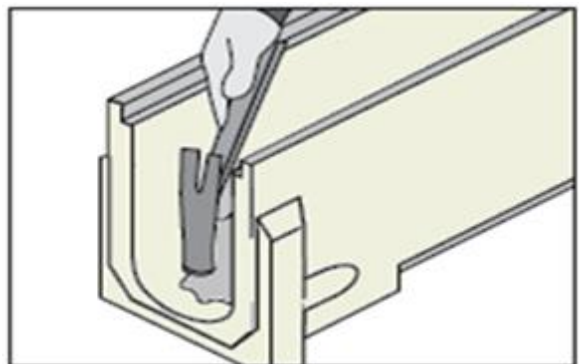

CAUTION: Do not hammer directly on material to make penetration or remove knockout. This may cause severe cracking of material surrounding hole. **ALWAYS** **PREDRILL SWITCH HOLES.**

1. A grinder may be used to dress or enlarge hole for proper pipe or channel insertion.

If no end outlet is provided a pipe may be fitted into hole using appropriate sealant/adhesive.

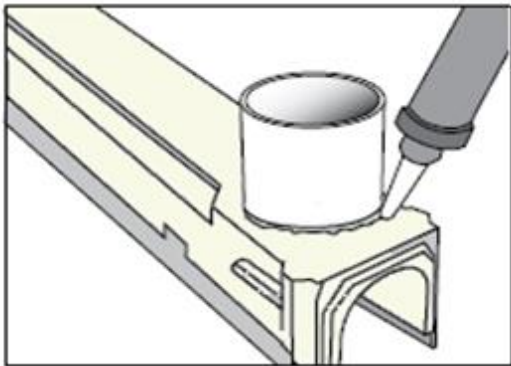

End Caps, End Outlets and Bottom Outlets

End Caps, End Outlets, and Bottom Outlets are field fabricated by first fitting end cap, end outlet or bottom outlet to channel and then removing the unwanted piece. Each end cap or outlet is factory scored along predetermined measurements.

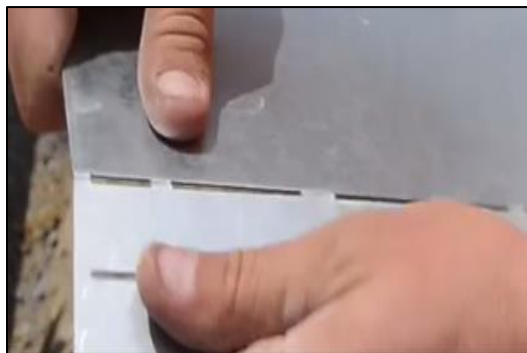

5. Connection with Underground Piping

Channels may be connected directly to underground piping via:

- 1) End cap outlets (horizontal outlet).



- 2) Bottom Outlets (vertical outlet)



- Turn the channel upside down.
- Make the required penetration by either core drilling or switch drilling the needed opening.
- The no hub bottom outlet is then attached directly to the channel bottom using the appropriate sealant or adhesive.



If corrosive liquids are transported in trench, ensure sealant or adhesive is chemically resistant.

On some projects VOC's, and any off gas'ing from adhesives and sealants is limited or not allowed. In these cases, outlets, end caps, and other accessories may be held in place during the pour by the application of a suitable tape. In this example duct tape is used.

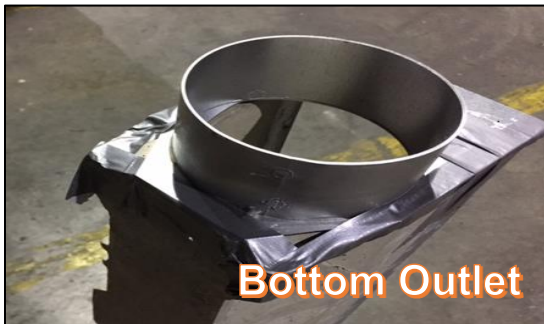

3) In-line catch basin.



Connecting Channels to Catch Basins

Catch basins have guides for channel connection at depths corresponding to invert level of designated channel units (0, 5-0, 10-0, 20-0).

In-line catch basins - cut out the end material at required channel height. Seal joint with flexible sealant.

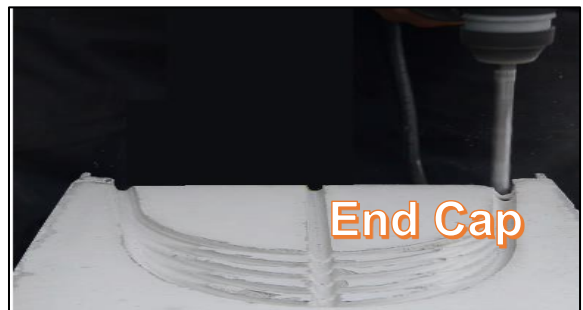



If corrosive liquids are transported in trench, ensure any sealant or adhesive is chemically resistant.

Combining multiple size channels into a single catch basin.

The Adapt-a-plate is needed when a 12" channel is combined with a 4" / 100mm, 6" / 150mm, or 8" / 200mm channel into one large Pro 300 catch basin. This provides the designer the ability to run several different channel sizes all discharging into a single common catch basin.

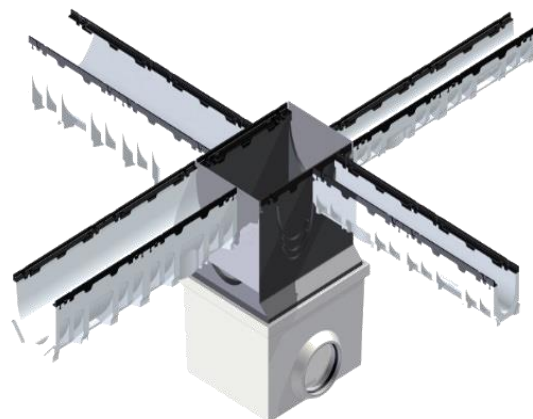
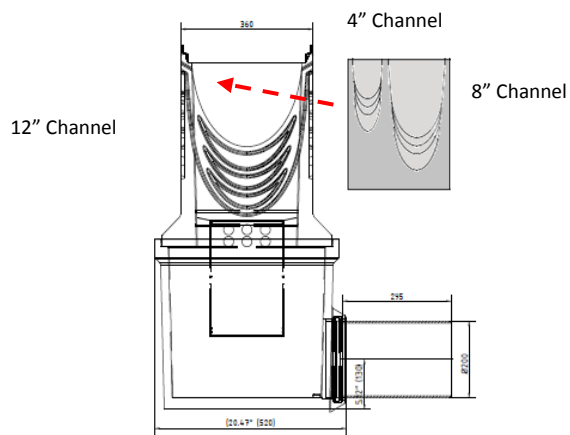

6. Positioning of Channels

Start at outlet point or end of the run which will be the discharge point.

Ensure the string-line, or laser is set at the top edge of the required channel height.

Lay channel out according to engineer's diagram. Follow directional arrows. Installing slopes in sequence of number.



Channels should be installed in accordance with engineered drawing, manufacturer's supplied drawing or in accordance with industry standards and area codes.

200 Series Channels are push fitted together. Simply align the male and female ends and push together.

200 Series channels can be laid out using all neutrals or with a predetermined slope. Refer to engineered drawings or manufacturers drawings for layout design.

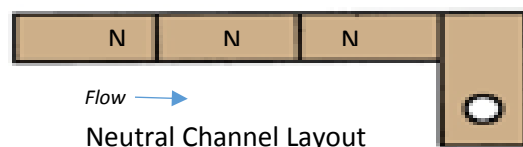



Each Channel is labeled as seen below. Note the directional arrow which will be found on all sloped channels. This indicates the intended direction of discharge. Channels should always be arranged so the flow path moves in the direction of the directional arrow.



The channel slope identity is marked on the label in the following location. Each channel will be marked with either the letter "N" for neutral or a number indicating its place in the sloped design. Always refer to the engineered or manufacturers drawing to determine correct channel placement and design.

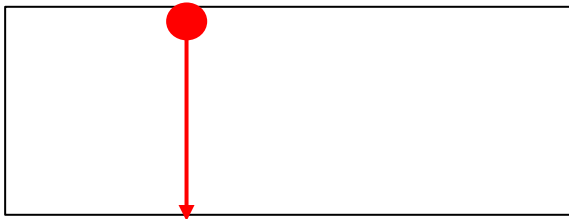

Common methods of positioning channels in the excavation include:

- A. Patty Method
- B. Mechanical Support Method
- C. Suspension Method

A. Patty method

- a) Set catch basin and channels on risers of brick or block to the required height (see page X for concrete dimensions).
- b) Connect and seal outlets, pipe, and end caps. All connections for water discharge should be made.
- c) Using low slump concrete or dry concrete, create 'patties' around the support risers. Allow "patties" to set.

Note: Patties should be sized to provide a complete support structure of concrete for riser and channel (see page x). Cover risers completely, and at least, two inches up the channel surface.

- d) If channels are to be sealed, roughen ends and use a flexible sealant – check chemical compatibility, as required.

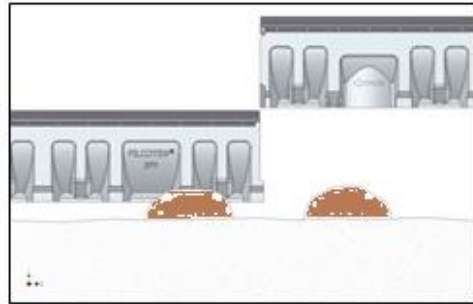

- e) Lower channel vertically onto 'patties' and position to correct height and alignment ensuring 'tight' connection to previous channel. Note channels are formed with interlocking male / female ends. Keep concrete, dirt and debris from inside channel joint.



- f) Ensure concrete “patties” extend and cover the top of ‘keys’ on side of channel - this helps prevent movement, or floating, during concrete pour. Once dry concrete is set the final pour can be made.



- g) Continue to lay channels until end of run or next catch basin is reached.

B. Mechanical Support Method



The rebar support makes height adjustment and positioning easy. A clamping system that fits around the profiled channel details.

Rebar is used to achieve the correct height.

One device per joint is required; 100, 150 & 200 wide versions available.

To complete an installation using rebar clips the installer will need one more clip than channel. If the project calls for 10 channels 11 clips will be needed.

1. Drive #4 or #5 rebar into ground to hold the installation rebar support. Screw installation device to rebar at required height. Use wing nut A.
2. Set channels in position so that fixed clamp fits into recess in channel end. Component C.
3. Push adjustable clamp tight onto other side of channel. Component C.
4. Adjust all wing nuts and fasteners so that the channels are held securely at the correct and level installation height. Wing nuts A and B.

5. Repeat for additional channels.
6. Each clip secures 2 adjoining channels which sit on top of the rebar clip and in-between the clip clamping teeth. Rebar clip is positioned at the channel seam.

Check that channels are at required level.
Wing nuts and fasteners must be fully adjusted and tightened on rebar as required to support load.

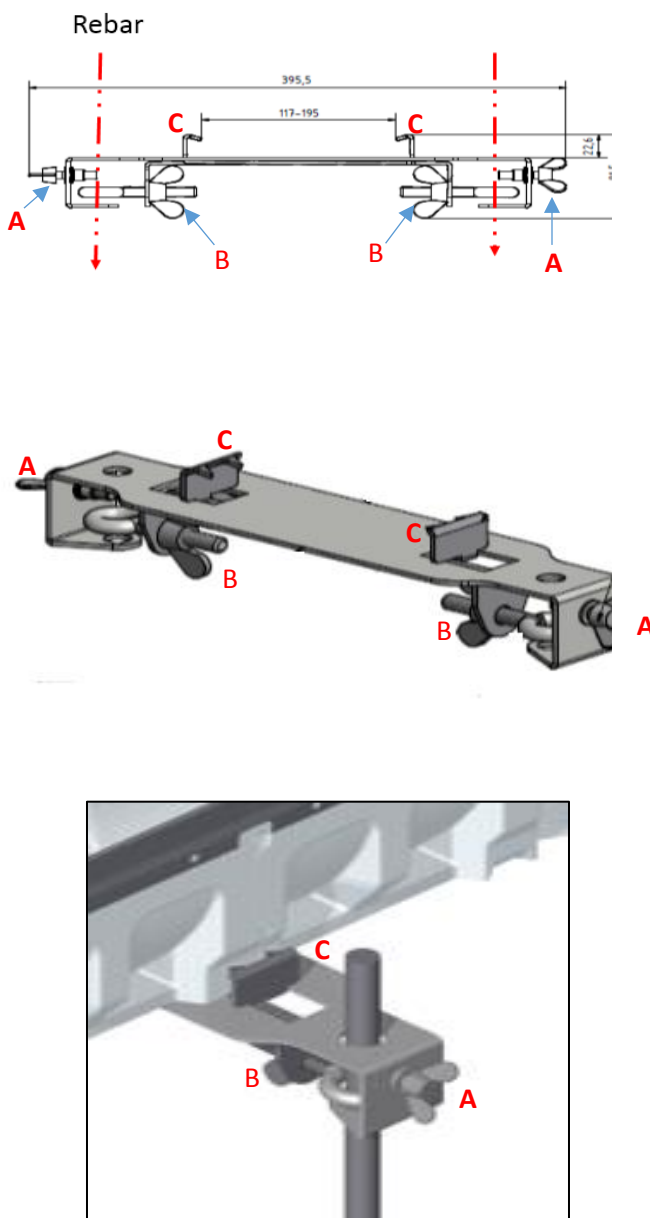

C. Suspension Method

- a) Cut 2 x 4's to length to span excavated trench or form boards (minimum 2 per channel - NW200 & NW300 will require 3 - 4 per channel). Cut 'spacers' to 'lift' supports above finished level.
- b) Using simple wire or straps suspend the channels from the overhanging support board.
- c) Adjust channels to required position and height. Packing material may be required beneath 2 x 4's to achieve required height and to ensure channels are level.
- d) If channels are to be sealed, roughen ends and use a flexible sealant – check chemical compatibility, if required.



- e) Nail or bolt cross member supports securely to slab/form boards. This ensures channels are held securely during concrete pour. **There is a real possibility that the channel run could float or shift if supporting cross members are not anchored.**

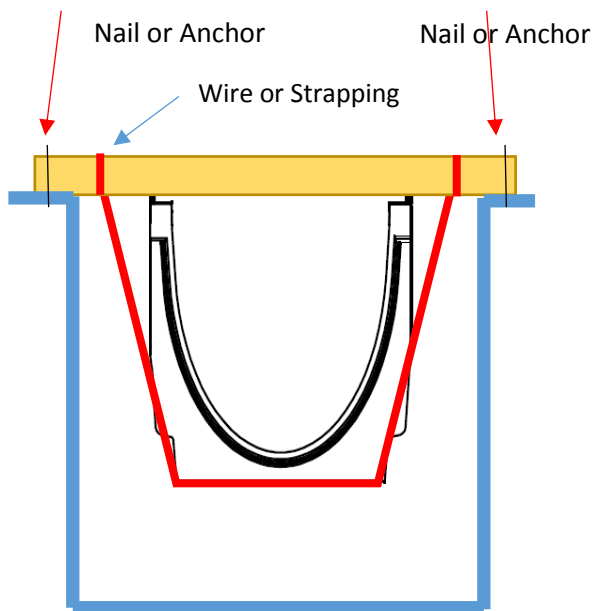

7. Pouring Concrete

Channel Bracing

To prevent channel wall and joints from distorting due to the weight of concrete, gratings or 3/4" plywood sections (cut to create a snug fit) should be placed in the grate rebate of channel.

If gratings are used, they should be suitably protected from concrete contamination during concreting (wrapped in plastic or masking tape) and should be laid to bridge channel joints to aid alignment. Shims (or washers) should be placed along one side to maintain a clearance gap.

Concrete Pour

To prevent concrete from filling channel body, cover open areas with plywood or similar (bracing should suffice).

If any open outlet exist these should be covered to prevent fresh concrete from entering the channel. All system connections are made and secure.

Concrete should have compressive strength of minimum 4,000 psi.

If using hanging method, once channels are secured in position, the first concrete lift should come approx. 2 inches (50mm) up sides of channels.

Once concrete 'patties' or first fill has been poured and set, remaining concrete surrounding can be poured.

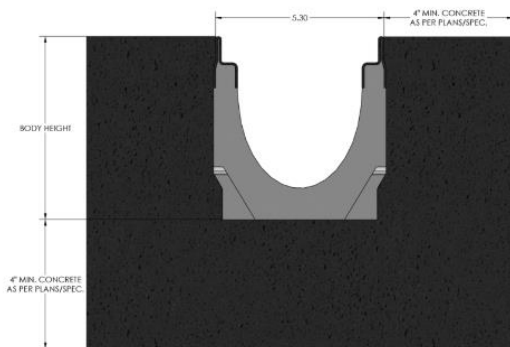

Concrete should be poured evenly on (both sides of channel) and carefully to avoid dislodging or moving channels.

A wand type concrete vibrator should be used to ensure concrete distributes evenly underneath and around channels.

If 'cold joints' are a concern, **engineering advice should be sought** to determine alternative details.

8. Pavement Finishing

a. Concrete

To finish installation, trowel concrete flat and taper down to channel edge.

The top of adjacent pavement must be above the grating level (approximately 1/8"), this ensures all liquids drain into the channel.

Once concrete has cured 24 hours, remove bracing and/or grate protection.

Expansion joints Transverse joints (perpendicular to the channel) are required to prevent surface cracking in the slab.

Such joints should be positioned at the channel joints to prevent channels from cracking. If such spacing is not possible, a cut must be made at the appropriate location through the channel and sealed with flexible sealant.

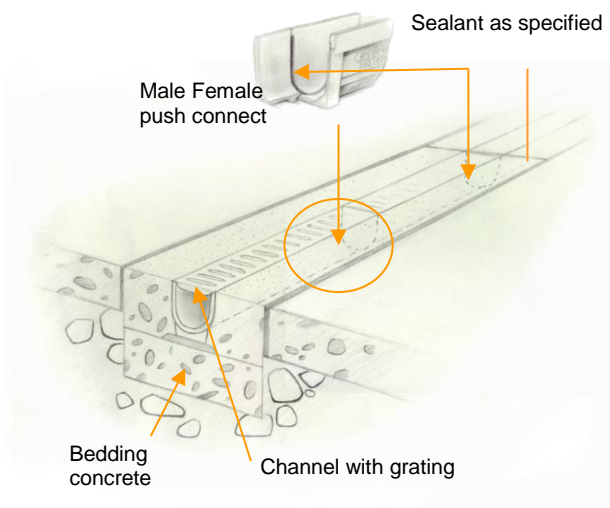

Longitudinal Expansion / Control Joints should be continuous and flexible. They must be provided between the concrete and surrounding slab and may be varied to suit concrete surrounding width by up to a meter (3 feet) from the channel.

Hydro BG strongly encourages installation of expansion joints in accordance with Engineer specification, local codes and regulations.

b. Asphalt

For applications up to Load Class C, asphalt can be applied directly up to channel edge.

For applications over Class C a full concrete surround should be used.

See page x for concrete haunch details.

CAUTION: To prevent damage to channels and grates, protect channel between concrete pour and application of asphalt and when rolling asphalt.

Asphalt must be above grating level by approximately 1/8", this ensures all liquids drain into channel.

Once installation is finished, remove bracing and/or grate protection.

c. Brick Pavers

For applications up to Load Class C, brick pavers can be installed up to channel edge.

For applications over Class C a full concrete surrounding should be used. See page x for concrete haunch details.

Brick pavers adjacent to channel **MUST** be fully bonded to concrete haunch. This prevents the movement of bricks and

possible damage to channel. Subsequent pavers can be bedded on compacted sand. Bricks must be above grating level by approximately 1/8", this ensures all liquids drain into channel.

Once surface is finished, remove bracing and/or grate protection.

9. Fit Grates

Gratings installation

The FILCOTEN gratings are equipped with a four point fix self-locking (Snap-on) system and/or four point bolting system.

To install grating, align it directly over channel rails. Push down/stand on grating until clicks into position.

If the gratings are equipped with bolting system, use the key driver to lock them in place.



To remove first grate, insert a flat head screw driver under grating bar, pull up sharply.

Subsequent grates can be removed by hand.

- Grip end of grate and lift sharply.
- If the gratings are equipped with bolting system, use the key driver to release.

Anti-vandal locking device

Step 1: Push the system to protect against vandalism into the fitting springs provided for this purpose until it snaps into place.



Step 2: Attach the grating as described for the fix-connection below into the 200 Series tec/pro channel.

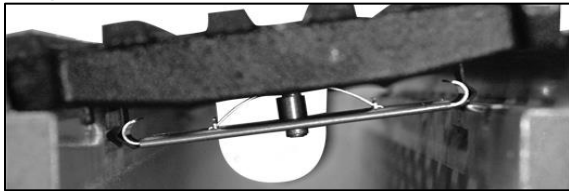

Step 3: Push the grating firmly into the channel until it snaps into place.



Step 4: Lock the system to protect against vandalism by twisting the bolt.

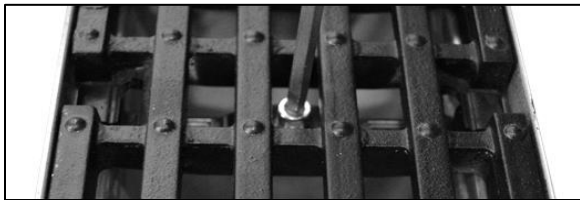

1. Remove any debris in system and grate rebate. Ensure outlet pipes are clear.
2. Install sediment buckets in catch basins, if required.
3. Flush trench run to check for pipe flow blockages, unblock if necessary.
4. Empty sediment buckets and clean out pipe connections, if necessary. Replace sediment buckets.



5. Install gratings in proper position ensuring they are securely locked down if required (page x).

Drainage system is now ready for use.

10. Final Inspections & Maintenance

Final Inspections

Maintenance

Regular inspections of trench drain system is recommended. Frequency will depend on local conditions and environment, but should be done at least annually. Inspections should cover:

- Grates and locking devices
- Catch basins and sediment buckets
- Surrounding concrete and adjacent paving

All items should be inspected for damage, blockage or movement. Compare with site drawings if necessary.

1. Remove grates - see page x.
2. Remove debris from channel.
3. Flush channels with water or high pressure washer.
4. Repair damaged surfaces.
5. Renew joint seals as required.
6. Empty sediment buckets and clean out pipe connections.
7. Re-install sediment buckets.
8. Re-install grates, ensuring they are locked in place.

Systems with grates which may have wide slots may be cleaned with the use of pressured water applied through the grate - debris will be washed to catch basin for removal.

(Empty and replace sediment bucket).