

TRENCH DRAIN SYSTEMS

6" Trench Drain

Install Guide



1 Gather the tools and materials for the installation

- Shovel
- Hammer
- Butyl caulk or adhesive silicone sealant
- Caulking gun
- Stringline
- Level or laser line
- Phillips screwdriver
- Concrete vibrator
- #4 rebar (1/2")
- Tie wire and self-tapping screws
- Pliers and cordless screwdriver

Caution: Observe all safety precautions when you are operating electrical tools or hand tools.

2 Excavate a trench for the channels

Excavate a trench with a minimum concrete-surround, by load class:

- Class A: each side 4", depth below 4"
- Class B: each side 4", depth below 4"
- Class C: each side 6", depth below 6"
- Class D: each side 8", depth below 8"

Note: The channel must be recessed 1/8" for pedestrian traffic and 1/4" for vehicular traffic.

Note: The channel must be surrounded on all sides by a minimum of 4" of concrete for a Class A installation. For a complete description of installation types, see **Load Class Installation** on **page 4**.

Questions: 646-227-0910
info@trenchdrainmaterials.com

3 Lay the channels alongside the trench

- Start the layout at the drain outlet with the deepest (highest numbered) channel section, proceeding to the shallowest (lowest numbered) channel section.
- Point the arrows on each channel section towards the drain outlet.

Note: Channel sections marked with an N are neutral non-sloped channel sections; for example, DS-090N or DS-100N.

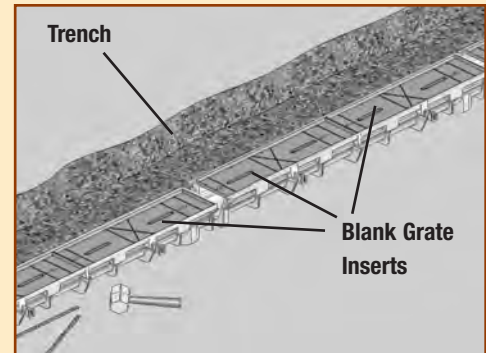

Channel Layout

4 Locate the expansion joints

Plan to install expansion joints parallel and perpendicular to channel according to plan specification.

Note: Locate perpendicular expansion joints crossing the channel at the channel joints (if possible).



Expansion joints

5 Assemble the drain outlet

- Assemble the drain outlet with a DS-224 End Cap, drill out the channel bottom outlet, and install a DS-126 bottom outlet adapter (if necessary), or
- Assemble an End Outlet DS-227, or
- Assemble a Catch Basin DS-340.
- Use End Cap DS-224 at the shallowest end of the run.
- Set a string line in the trench along each side of where the channel will be placed, at final elevation of channel. If using ductile iron frame, place string line 1" below finished grade to accommodate the frame.

Note: Bottom outlets, drain outlets, and catch basins connect to the deepest end of the run.

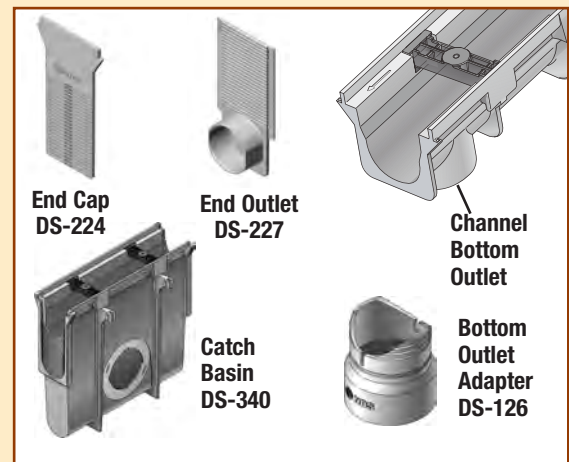

Drain outlets

6 Assemble the channels

Note: If using Ductile Iron Frames skip to **Step 6A**.

The outlet will be at the deepest end. Assemble the channel section from the deepest to the shallowest.

- Remove the screws from the end of the Blank Grate Insert located on the male side of the channel (do not remove the center screws from the insert). Start at the drain outlet.
- Place a bead of butyl caulking or silicone sealant in the channel's joint or groove (if a water tight seal is required).

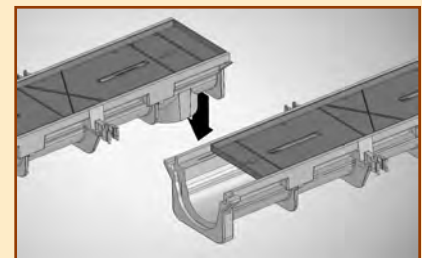

Joined channels

- Snap the channel sections together in multiples of two.
- Loosen the center screws on the Blank Grate Insert; slide the Insert in the direction of the male end (downstream) so it overhangs or is staggered.
- Align channel with Blank Grate Insert for straightness. Use self tapping screws to fasten the Inserts to the channel; ensure the ends are flush with the edge of the Insert. Cover the slots on the Insert with tape to prevent concrete from getting into the channel.
- Place the pre-assembled channel sections in the trench beginning from the outlet end.

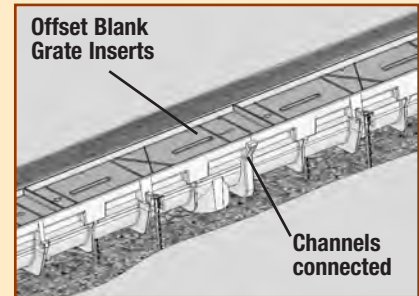

Offset blank grate inserts



Tip: Cover screw heads in the Blank Grate Insert with tape for easy removal after the concrete is poured.

6A If using Ductile Iron Frame - assemble the channels

The outlet will be at the deepest end. Assemble the channel section from the deepest to the shallowest.

- Remove all Blank Grate Inserts from the channel sections.
- Place a bead of butyl caulking or silicone sealant in the joint or groove (if a water tight seal is required).
- Snap the channel sections together in multiples of two.
- Place the pre-assembled channel sections in the trench beginning with the outlet end.
- Secure the Ductile Iron Frames to the channel using the DS-123 screws. Install iron grates using DS-225 screws.
- Apply a covering or tape to the grates for protection and to prevent concrete from entering the channel.

7 Install the rebar for each channel section assembled

- Insert rebar into the Leveloc rebar support. Drive rebar straight into the ground about 6" to 12" or until rebar is firmly held in place.
- Set channel to desired grade level and align for straightness using string line.
- Continue attaching pre-assembled channel sections and install rebar until run is complete.
- Proceed with final adjustments for grade level and straightness using tie wire or self-tapping screws; secure rebar to the Leveloc rebar support.

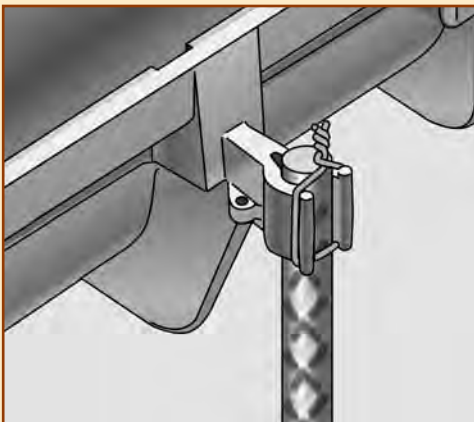

Wire support

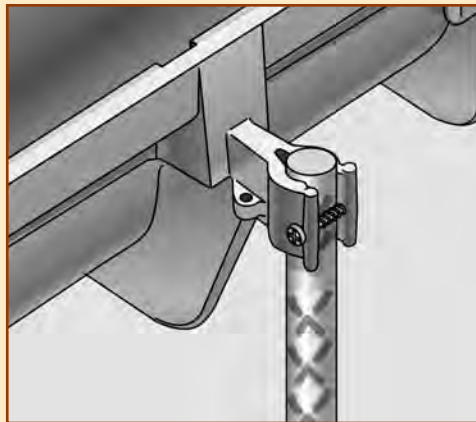

Screw support

8 Cradle the channel with concrete

- Place concrete around base of rebar posts on each side of the channel as well as underneath the channel between the rebar posts.
- Repeat concrete cradle for each pair of rebar posts.

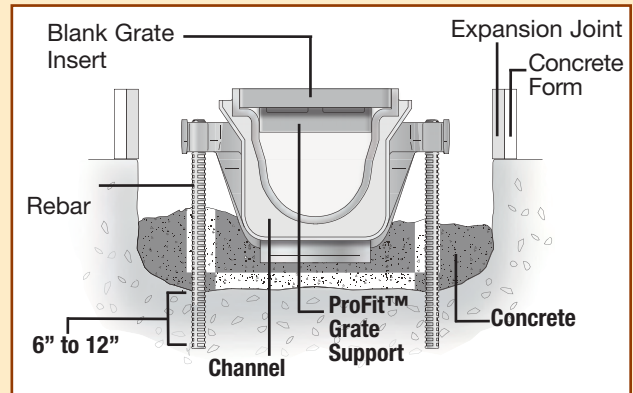

Concrete cradle

9 Pour the concrete in the channel trench

- Pour equal amounts of concrete on each side of the channel to prevent it from shifting.
- Vibrate the concrete to avoid bubbles or voids.



Tip: Installations in asphalt require the same concrete encasements.

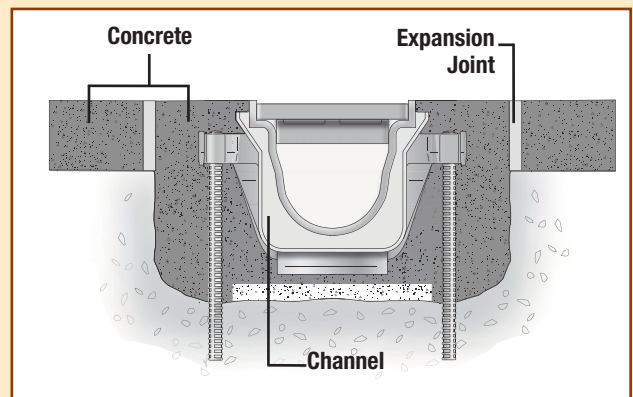

Channel cross-section for pour

10 Clean up the installation

- After the concrete has set for a minimum of 24 hours, remove the Blank Grate Inserts.
- Install the grates.
- Ensure that the grates are securely fastened.

Note: Follow the concrete manufacturer's recommendations for set-up time and loading.

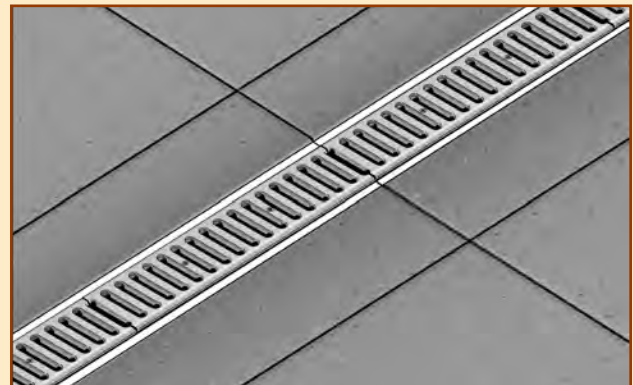

Finished installation

Load Class Chart		Concrete Thickness	
Rating	Traffic	Each side	Depth below
Class A	Pedestrian traffic	4"	4"
Class B	Light traffic	4"	4"
Class C	Heavy duty traffic	6"	6"
Class D	Heavy duty traffic	8"	8"

Questions:
646-227-0910
info@trenchdrainmaterials.com



Slip joints for fast and easy connections

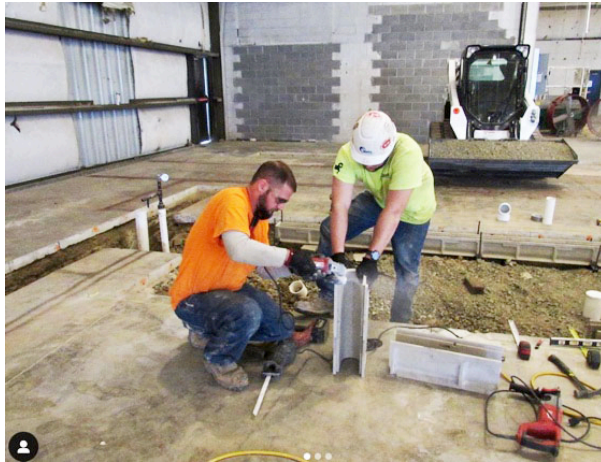

Lightweight and easy to handle



Rebar attachments prevent floating